

June 6, 2024

Williston Development Review Board  
c/o Planning & Zoning  
7900 Williston Road  
Williston, VT 05495

RE: Discretionary Permit Application  
99 Engineers Drive Building Addition  
99 Engineers Drive, Williston

Please find attached a Discretionary Permit application and supporting materials for a 2,300 s.f. building addition to the existing 7,080 s.f. building located on 99 Engineers Drive. The proposed project involves the construction of two additional garage bays located on the southern end of the existing building to be used by Engineers Construction for vehicle repair and maintenance, including a pressurized vehicle wash system.

The existing building has had two tenants for many years, White's Truck & Auto Repair and Korpi Truck Service. White's Auto Repair occupies approximately one quarter of the building space and is located in its northeastern area. The vehicle storage areas located along the northern and northeastern parts of the site are associated with this business. The remainder of the building has been occupied by Korpi, with the vehicle storage areas along the southern and eastern parts of the site associated with this business. Recently, Korpi has moved its business out of the building and has removed the vehicles which it had stored around the site.

Engineers Construction is in the process of occupying the remaining building area formerly used by Korpi Truck Service and proposes to construct the new building addition which will match the exterior appearance and height of the existing building. The new building addition will not increase the total impervious area on the site since it is located within an existing gravel area. The building addition and associated area of construction will be less than 0.25 acres and will not cause any soil disturbance.

### **Vehicle Wash System**

The Project proposes to install a pressurized vehicle wash system within the new addition to be used by Engineers Construction's fleet of vehicles, see Vehicle Wash System Specifications. The water from the vehicles will be collected into a floor drain which will connect to two 2,500-gallon HD pre-cast concrete tanks located outside of the building. The washwater will first enter into a 2,500 gallon Grit/Oil Separator Tank before entering into a 2,500 gallon Holding Tank equipped with floats which will activate a 75% Warning alarm and Tank Full alarm. The tanks will be pumped out as needed and disposed of at an approved disposal facility, see sheets C-2 Site Plan and C-3.1 Details for further information.

### **Parking**

The Project's proposal to provide 8 parking spaces (80% of the required spaces) was approved during the Pre-Application review. Two of these spaces would be in the existing paved parking area north of the building, and the remaining six spaces would be in the existing paved parking area adjacent to Engineers Drive near the southwestern corner of the property. There is additional gravel parking around the building, but no assigned parking areas. The project proposes to install two inverted-U bike racks to provide short-term bicycle parking. Within the existing building there is a storage room which will be used to provide three spaces for long-term bike parking, and an existing bathroom with shower to provide one end-of-trip facility, see sheet C-2 Site Plan and existing building floor plan for locations.

### **Setbacks/Fencing**

The Project is abutted by commercial/industrial properties to the south and north, Engineers Drive and commercial/industrial properties to the west, and an undeveloped conservation area to the east. The Project's proposal to provide 9' setbacks along the sides and rear of the property was approved during Pre-Application review, and the front yard setback was determined to be 23 feet from Engineers Drive. The Project's proposal to connect the new chain link fence and new gate with the existing chain link fence located within the 23' front yard setback from Engineers Drive was approved during Pre-Application review, provided this does not increase the existing level of non-conformity.

### **Outdoor Storage**

Engineers Construction proposes to use the former vehicle storage areas on the site for outdoor storage. The outdoor storage areas are designated on the Site Plan and will be located outside of the 9' setbacks along the northern, southern and eastern sides of the property. Concrete blocks or boulders will be used to demarcate the 9' setback on the eastern side of the site to mark the extent of the non-conforming outdoor storage areas within the watershed protection.

### **Landscaping**

There are two street trees located in the grassed area between the existing building entrance and Engineers Drive. Due to the existing gravel area around the site and its location in an industrial area, the Project's proposal not to provide any additional landscaping along the setbacks was approved during Pre-Application review, with the understanding that the existing ash street tree will be removed and replaced with a different species if it becomes unhealthy due to Emerald Ash Borer.

### **Lighting**

The existing building has four RAB W34 Wall Pack shielded light fixtures mounted at a height of 15 feet. Once the Project is completed, there will be six total building-mounted light fixtures which will be motion-activated and programmed to turn off 5 minutes after motion is last detected. The existing building will have the two existing light fixtures on its western and northern sides. The new addition will have four building-mounted light fixtures, two of which will be new light fixtures and two which will be relocated light fixtures from the existing building. The lighting illumination levels will meet the Outdoor Lighting standards of Chapter 24, see Lighting Plan by RAB Lighting.

**Signs**

There are no new sign locations proposed for the property at this time. Engineers Construction may apply administratively for a sign permit in the future if it becomes the sole tenant of the building.

**Public Works**

The Project will apply for an additional 350 GPD water allocation from Williston Public Works for the pressurized vehicle wash system.

**Fire Department**

The existing building has both mailbox and building signage. An existing building floor plan has also been included with the application.

Please contact me if there are any questions/comments or any further information is needed.

Sincerely,

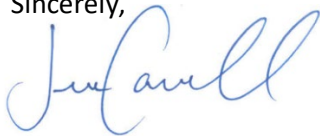

Jesse Carswell, P.E.



Color: Bronze

Weight: 6.6 lbs

<b>Project:</b>	<b>Type:</b>
<b>Prepared By:</b>	<b>Date:</b>

Driver Info		LED Info	
Type	Constant Current	Watts	35/25/17W
120V	0.30A/0.21A/0.15	Color Temp	3000K/4000K/5000K
208V	0.17A/0.13A/0.09A	Color Accuracy	73-75 CRI
240V	0.15A/0.11A/0.08A	L70 Lifespan	100,000 Hours
277V	0.13A/0.09A/0.07A	Lumens	2,728-5,574 lm
Input Watts	18.7-39.1W	Efficacy	131.3-153 lm/W

**Technical Specifications**

**Field Adjustability**

**Field Adjustable:**

Field Adjustable Light Output:  
35W/25W/17W (factory default 35W)  
Color temperature selectable by 5000K, 4000K and 3000K

**Compliance**

**UL Listed:**

Suitable for wet locations

**Trade Agreements Act Compliant:**

This product is a product of Cambodia and a "designated country" end product that complies with the Trade Agreements Act

**DLC Listed:**

This product is listed by Design Lights Consortium (DLC) as an ultra-efficient premium product that qualifies for the highest tier of rebates from DLC Member Utilities. Designed to meet DLC 5.1 requirements.  
DLC Product Code: S-4568AI

**Electrical**

**Driver:**

Constant Current, Class 2, 120-277V, 50/60Hz:  
35W: 120V: 0.30A, 208V: 0.17A, 240V: 0.15A, 277V: 0.13A  
25W: 0.21A, 208V: 0.13A, 240V: 0.11A, 277V: 0.09A  
17W: 120V: 0.15A, 208V: 0.09A, 240V: 0.08A, 277V: 0.07A

**Dimming Driver:**

Driver includes dimming control wiring for 0-10V dimming systems. Requires separate 0-10V DC dimming circuit. Dims down to 10%.

**THD:**

2.85% at 120V, 6.55% at 277V

**Power Factor:**

99.5% at 120V, 92% at 277V

**Photocell:**

Integrated photocell included with on/off switch

**Performance**

**Lifespan:**

100,000-Hour LED lifespan based on IES LM-80 results and TM-21 calculations

**Wattage Equivalency:**

35W: Replaces up to 175W Metal Halide or 150W High Pressure Sodium  
25W: Replaces up to 125W Metal Halide or 100W High Pressure Sodium  
17W: Replaces up to 100W Metal Halide or 70W High Pressure Sodium

**LED Characteristics**

**LEDs:**

Long-life, high-efficacy, surface-mount LEDs

**Color Uniformity:**

RAB's range of Correlated Color Temperature follows the guidelines of the American National Standard for Specifications for the Chromaticity of Solid State Lighting (SSL) Products, ANSI C78.377-2017.

**Construction**

**Housing:**

Die-cast aluminum

**Lens:**

Glass

**Reflector:**

Specular aluminum

**Cold Weather Starting:**

The minimum starting temperature is -40°C (-40°F)

**Maximum Ambient Temperature:**

Suitable for use in up to 40°C (104°F)

**Mounting:**

Die-cast backbox with four (4) conduit entry points and knockout pattern for junction box or direct wall mounting. Hinged door for easy re-assembly.

**Green Technology:**

Mercury and UV free. RoHS-compliant components.

## Technical Specifications (continued)

### Finish:

Formulated for high durability and long-lasting color

### Optical

#### BUG Rating:

35W: B0 U3 G3

25W: B0 U3 G2

17W: B0 U2 G2

### Other

#### 5 Yr Limited Warranty:

The RAB 5-year, limited warranty covers light output, driver performance and paint finish. RAB's warranty is subject to all terms and conditions found at [rablighting.com/warranty](http://rablighting.com/warranty).

#### Note:

All values are typical (tolerance +/- 10%)

#### Buy American Act Compliance:

RAB values USA manufacturing! Upon request, RAB may be able to manufacture this product to be compliant with the Buy American Act (BAA). Please contact customer service to request a quote for the product to be made BAA compliant.

## Dimensions

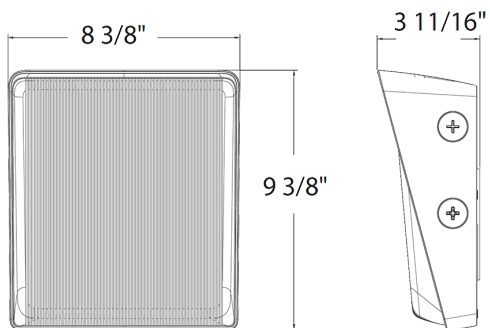

## Features

100,000-Hour LED lifespan

0-10V dimming standard

5-Year, limited warranty

## Ordering Matrix

Family	Size (Wattages)	Color Temp	Finish	Voltage	Options
W34	S				

S = Small (35/25/17W)  
M = Medium (80/60/40W)  
L = Large (150/100/75W)

Blank = 3000K/4000K/5000K CCT Adjustable

Blank = Bronze

Blank = 120-277V, 0-10V Dimming

Blank = Integrated Photocell



# Undercarriage Wash Systems

## Water Treatment Systems

*Making a positive impact on our environment for today and future generations.*

*WCU Series*

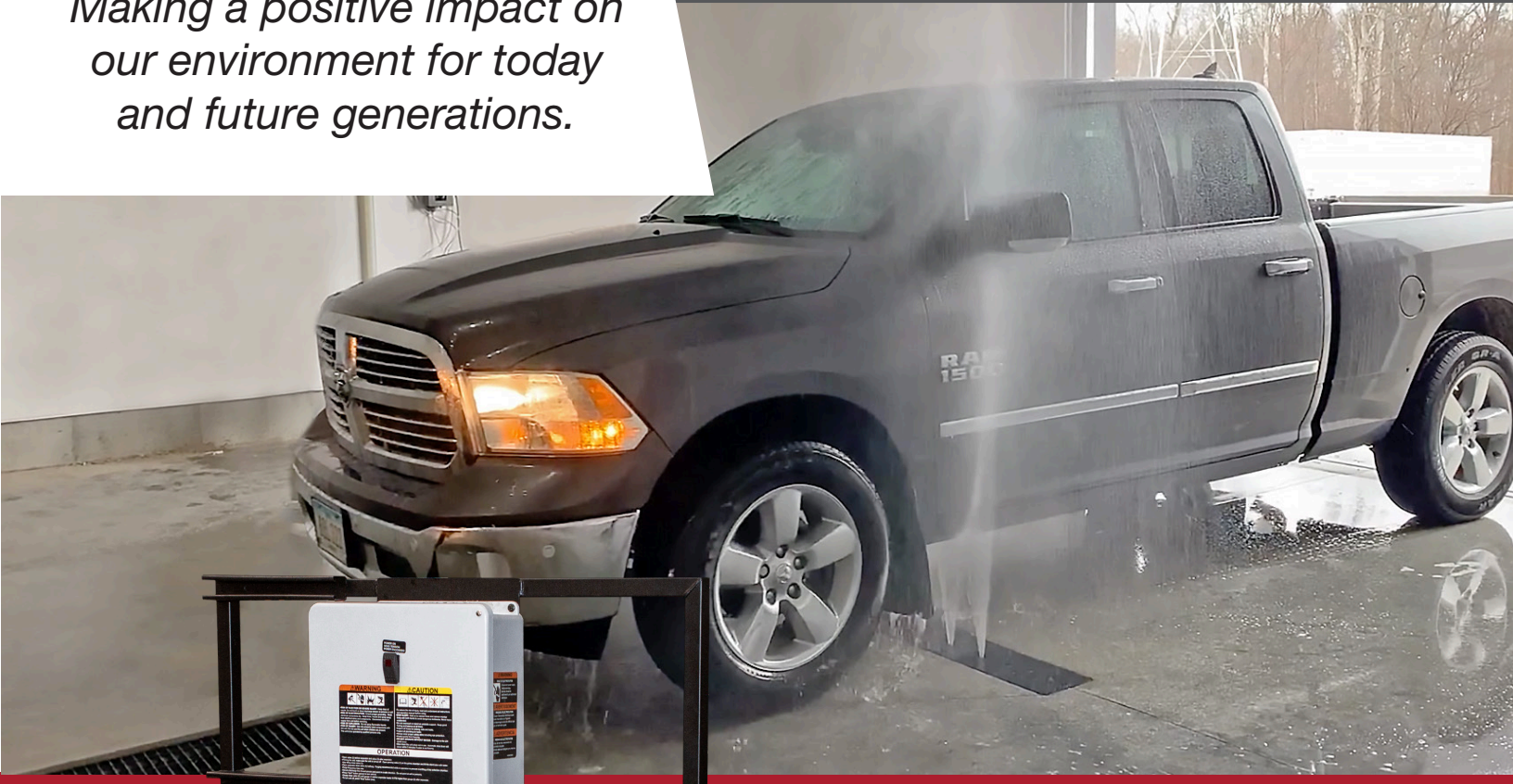

# WCU Series

## Undercarriage Wash Systems

THE IDEAL ACCESSORY FOR ANY WASH BAY, THIS SYSTEM HELPS TO REMOVE MUD AND GRIME BUILD-UP UNDER VEHICLES AND SMALL EQUIPMENT. BUILT IN THE USA, THE DURABLE STEEL FRAME ENSURES LONGEVITY EVEN IN HARSH CONDITIONS.

CUSTOM BUILT UNITS ARE AVAILABLE. CONSULT DEALER FOR MORE INFORMATION.



WCU-35-OME1

### FEATURES

- Powder coated frame with control box and pump
- 3-foot suction hose
- 8-foot stainless-steel spray bar with 16 nozzles
- Shut-off valve
- 250-gallon holding tank
- PLC controls for automatic pump operation with photo-eye and remote box
- ETL listed control panel
- Customizable covers and spray bars available

### CERTIFICATION

- ETL Certified – US and Canada



MODEL NUMBER	GPM @ PSI	PUMP	POWER REQUIREMENTS	SPRAY BAR COVER DIMENSIONS (LxWxH)	PUMP FRAME DIMENSIONS (LxWxH)	HOLDING TANK DIMENSIONS (WxH)	SHIP WT.
WCU-35-OME1	35 @ 110	3.0 HP	230V, 1Ø, 15.0A	96x6x0.5in.	4x3x5ft.	36x62in.	450 lb.
WCU-35-OME3	35 @ 110	3.0 HP	208-230V, 3Ø, 10.0A or 460V, 3Ø, 5.0A	96x6x0.5in.	4x3x5ft.	36x62in.	450 lb.
WCU-80-OME3	80 @ 70	7.5 HP	208-230V, 3Ø, 22.0A or 460V, 3Ø, 10.0A	96x6x0.5in.	4x3x5ft.	Consult Dealer	500 lb.

### ACCESSORY:

PART NUMBER	DESCRIPTION	FITS MODELS
18-0017	Nozzles – Sixteen 15°, size 15 nozzles, for high undercarriages	WCU-35-OME1 & WCU-35-OME3
18-0040	Nozzles – Sixteen 25°, size 40 nozzles, for high undercarriages	WCU-80-OME3

### OPTIONS:

PART NUMBER	DESCRIPTION	FITS MODELS
WX-0144	460V, 3Ø – Upgrades 208-230V model to operate at 460V	WCU-35-OME1 & WCU-35-OME3
WX-0146	Detergent – Adds chemical injector to bypass line of pump, chemical gets injected at inlet of pump	All models

# WCU Series

## Undercarriage Wash Systems



Sixteen 25°, size 15 nozzles spaced 6-inches apart, for low undercarriages

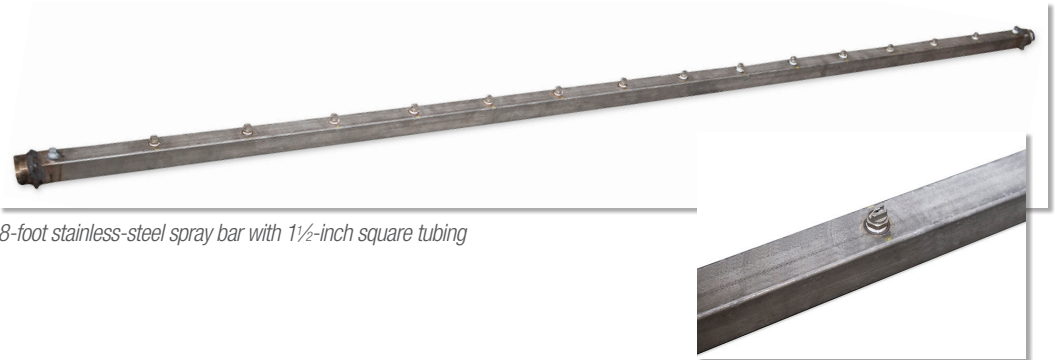

8-foot stainless-steel spray bar with 1½-inch square tubing



Remote box for auto/manual operation of spray bar

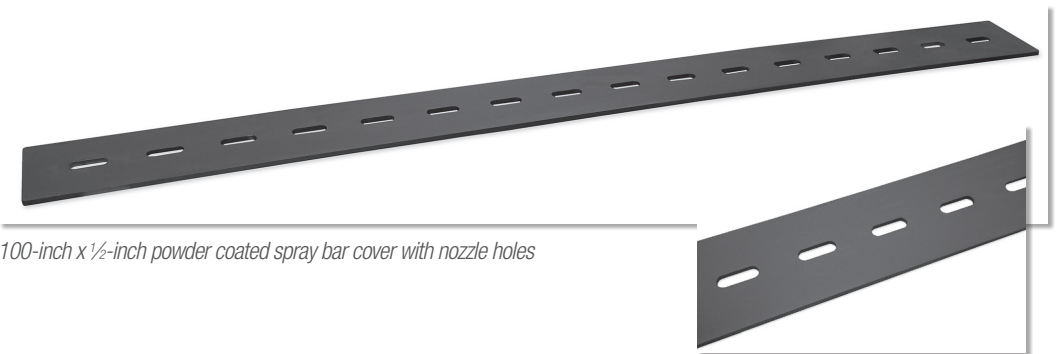

100-inch x 1½-inch powder coated spray bar cover with nozzle holes



Photo-eye with 10-foot maximum range

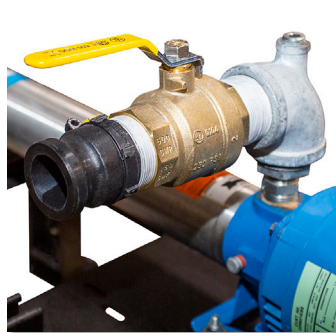

Shut-off valve



Auto flow control solenoid that opens water flow valve when system is on and closes when off to prevent drainage



250-gallon holding tank, with brass float valve and supply plumbing

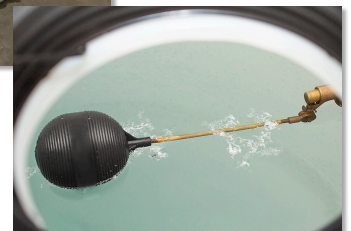

# WCU Series

## Process & Flow Description

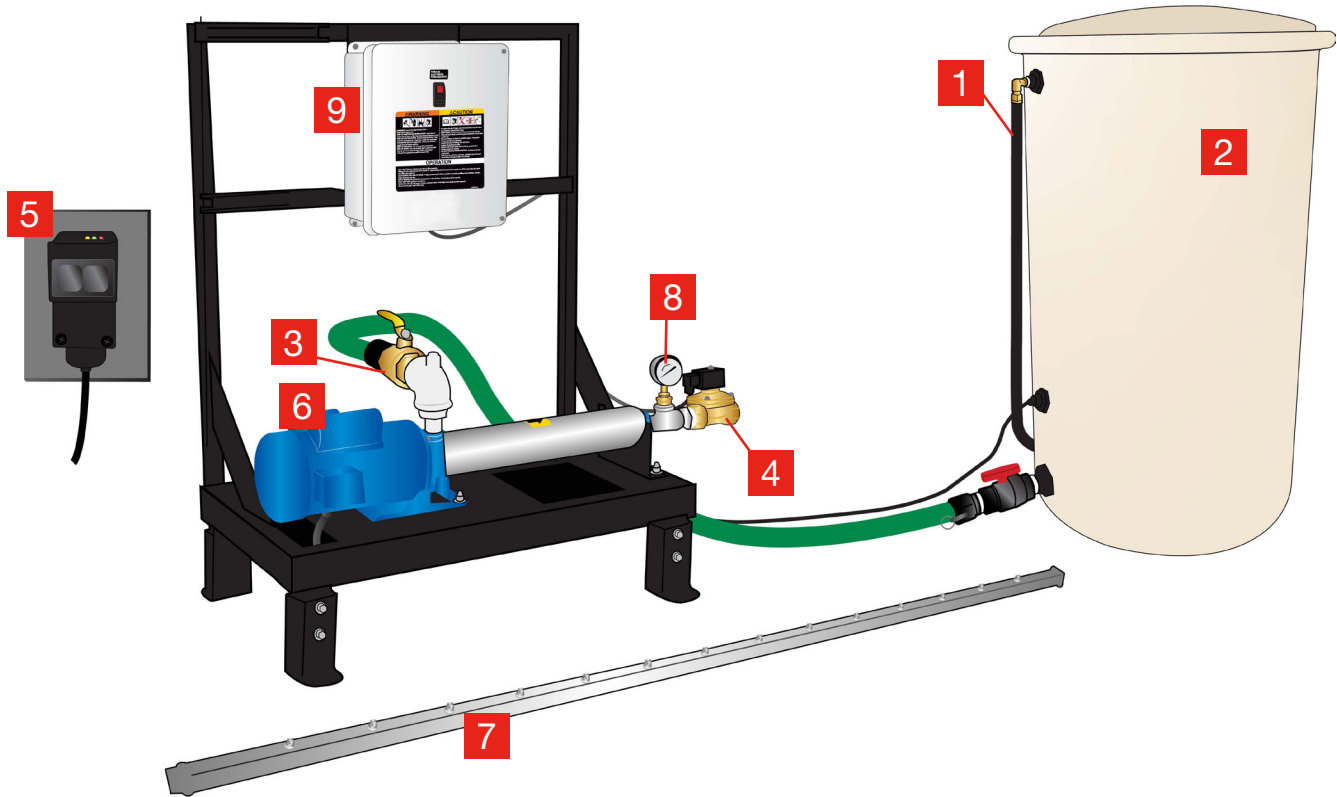

1. **INLET CONNECTION** – Connect a fresh water supply with at least 20-PSI to the water supply tank.
2. **WATER SUPPLY TANK** – A 250-gallon tank with an automatic water level float valve supplies water to the system.
3. **WATER SUPPLY VALVE** – Connects water supply tank to undercarriage wash system.
4. **AUTO FLOW CONTROL** – Opens water flow valve when system is on, closes when off.
5. **PHOTO-EYE** – Detects incoming vehicles and equipment and sends signal to start system.
6. **MULTISTAGE WASH SYSTEM PUMP** – A 3.0 HP, 13-stage centrifugal pump increases water pressure to 110-PSI to push through spray bar at 35.0-GPM.
7. **SPRAY BAR** – Provides upward high impact spray for undercarriage cleaning.
8. **PRESSURE GAUGE** – Measures pump pressure to monitor system performance.
9. **CONTROL PANEL** – ETL listed NEMA-4 rated corrosion-proof control panel for safe and reliable operation.

**McHenry**  
PRESSURE CLEANING SYSTEMS

100 Bucheimer Road | Frederick, MD 21701  
(301) 663-4683 | (800) 221-6905  
[www.mchenrypcs.com](http://www.mchenrypcs.com)